

TIGERGRIP | GX 55-50

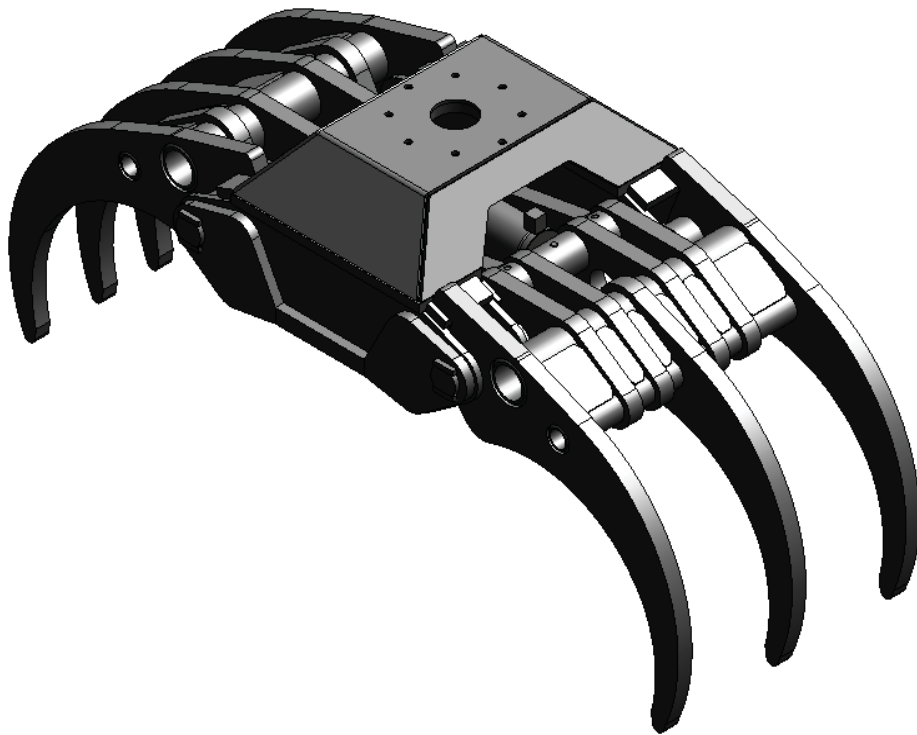

KEY FEATURES

- Heavy duty
- Double guide bars
- Optimized roll in/roll out properties
- High pressure cylinder with double piston rod seals
- High tensile wear resistant steel (400 HB)
- Extra reinforced body for rigid mounting - Excavator design

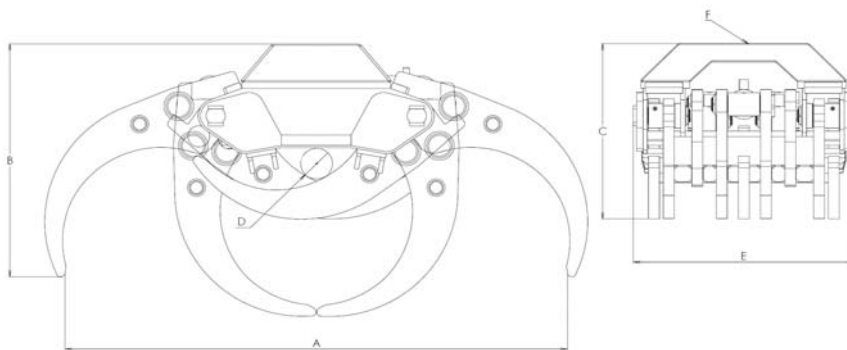

A	2295
B	1100
C	828
D	145
E	1010
F	340/8-20

MODEL SPECIFICATIONS



GX 55-50	1585	0,50	350	70	50	12	40	30		
----------	------	------	-----	----	----	----	----	----	--	--



Call for advice on:
e-mail us at:

0844 770 7969
sales@approvedhydraulics.co.uk