

TIGERGRIP / TG 22 UG-9

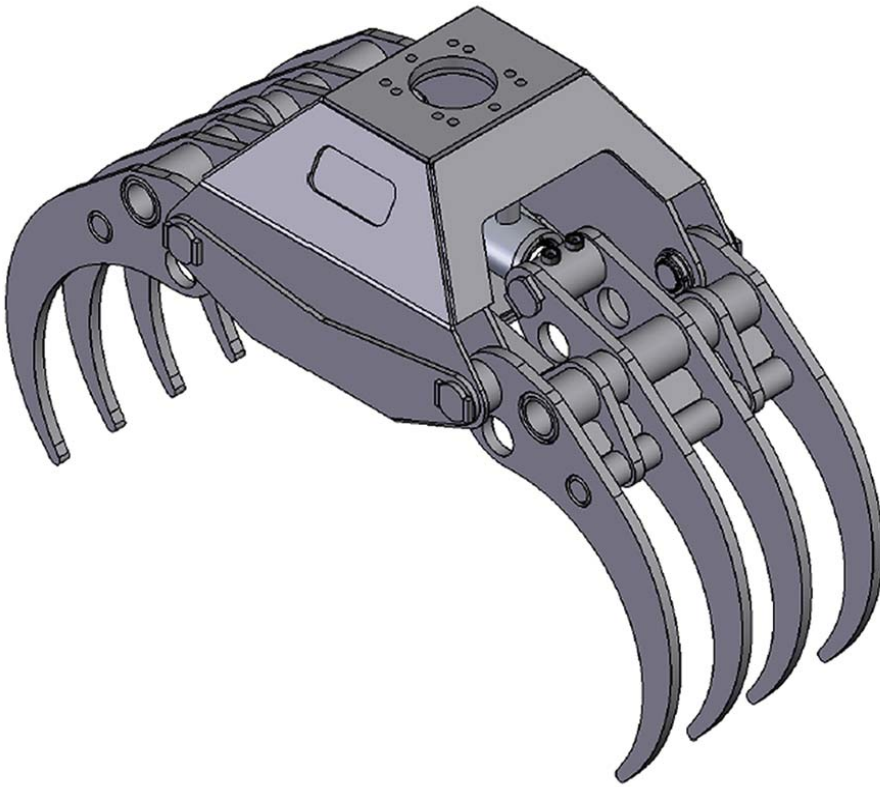

KEY FEATURES

- Heavy duty
- Double guide bars
- Optimized roll in/roll out properties
- High pressure cylinder with double piston rod seals
- High tensile wear resistant steel (400 HB)
- Extra reinforced body for rigid mounting - excavator design

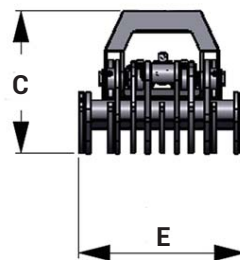
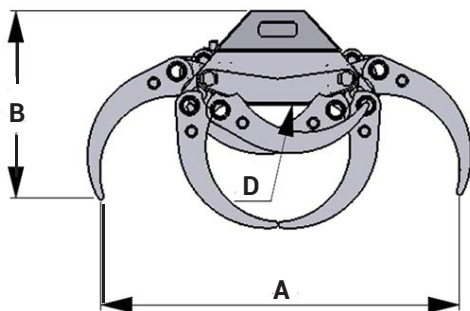

A	1085
B	855
C	582
D	80
E	568

MODEL SPECIFICATIONS



TG 22 UG-9

298

0,22

250

60

17

12

3

10

7

Call for advice on:
e-mail us at:

0844 770 7969

sales@approvedhydraulics.co.uk

