

TIGERGRIP / TG 28 UG-11

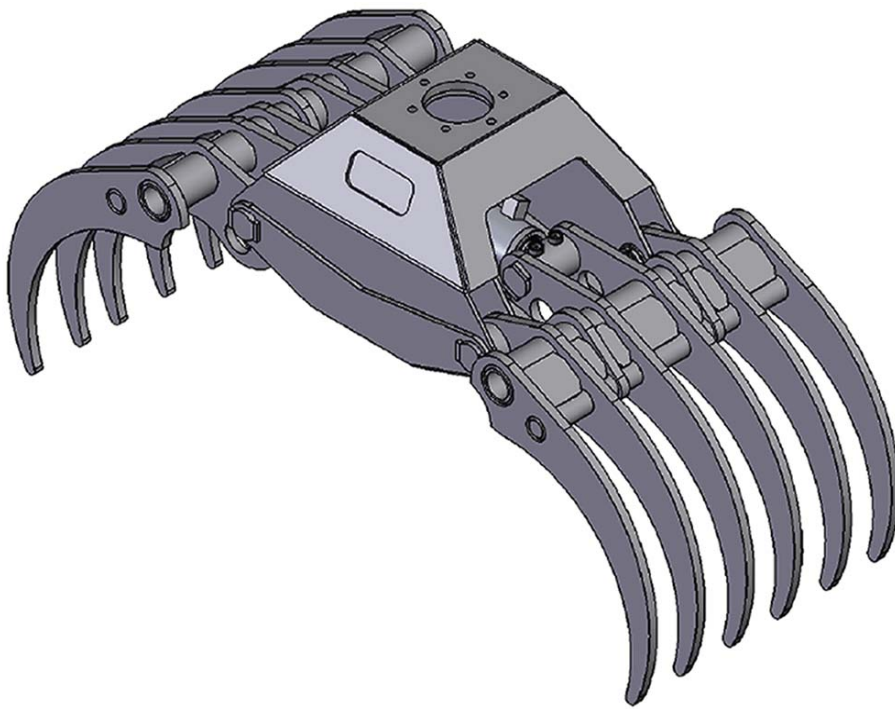

KEY FEATURES

- Heavy duty
- Double guide bars
- Optimized roll in/roll out properties
- High pressure cylinder with double piston rod seals
- High tensile wear resistant steel (400 HB)
- Extra reinforced body for rigid mounting - excavator design

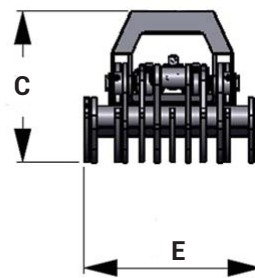
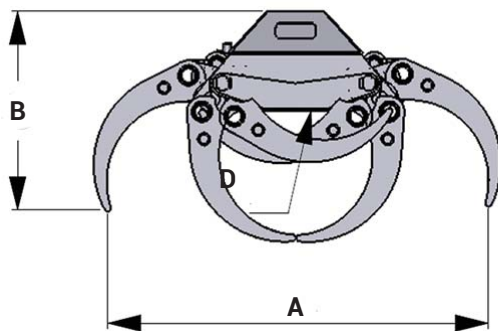

A	1520
B	788
C	604
D	90
E	730

MODEL SPECIFICATIONS



TG 28 UG-11

440

0,28

300

60

16,6

15

5

15

10



Call for advice on: 0844 770 7969 e-mail us: sales@approvedhydraulics.co.uk