

# TIGERGRIP | TG 16 PRO S

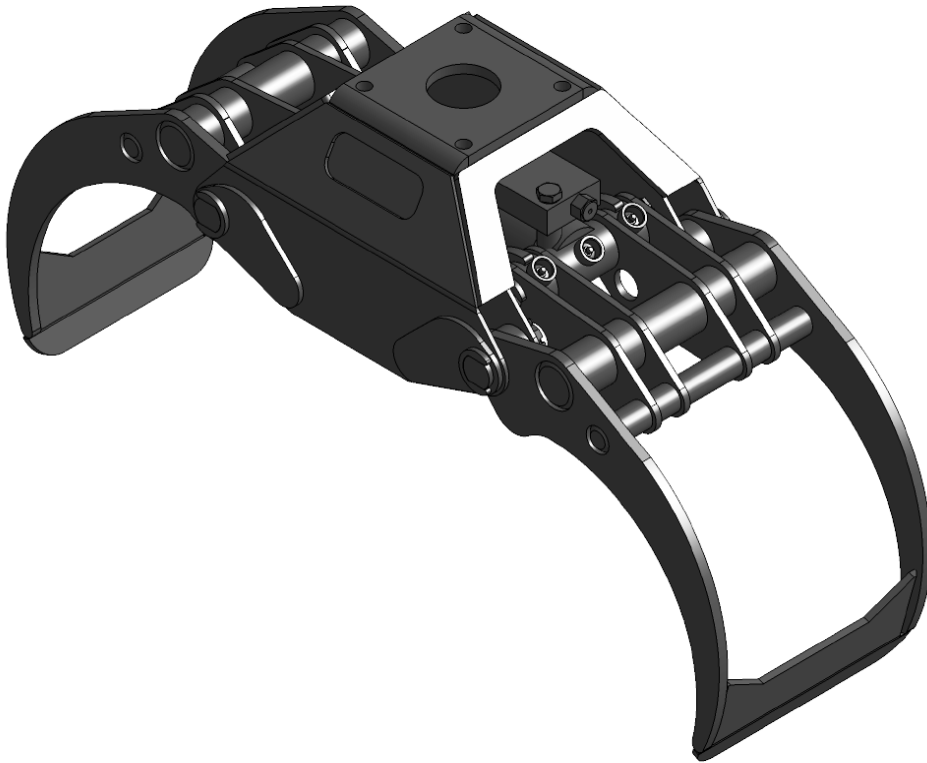

## KEY FEATURES

- Heavy duty
- Double guide bars
- Optimized roll in/roll out properties
- High pressure cylinder with double piston rod seals
- High tensile wear resistant steel (400 HB)
- Extra reinforced body for rigid mounting - excavator design

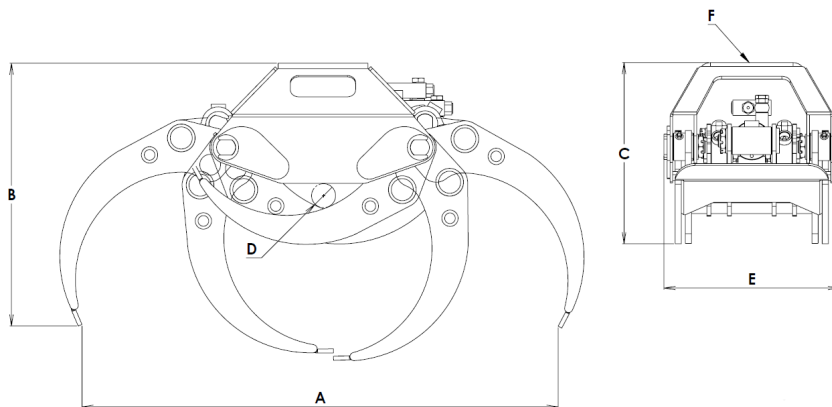

<b>A</b>	930
<b>B</b>	515
<b>C</b>	355
<b>D</b>	47
<b>E</b>	344
<b>F</b>	140/140-17

## MODEL SPECIFICATIONS



TG 16 PRO S	76	0,16	200	50	7	3	1	4	2,5	8		
-------------	----	------	-----	----	---	---	---	---	-----	---	--	--



Unit 15 Vauxhall Industrial Estate  
 Greg Street, Reddish  
 Stockport  
 SK5 7BR  
 United Kingdom  
 Telephone: 0844 770 7969  
 Fax: 0844 770 7979  
 web: [www.approvedhydraulics.co.uk](http://www.approvedhydraulics.co.uk)